

Office of Liquor and Gaming Regulation

Console Guidelines

Version 1.7



© The State of Queensland (Department of Justice and Attorney-General) 2023. Copyright protects this publication. The State of Queensland has no objection to this material being reproduced but asserts its right to be recognised as author of its original material and the right to have its material remain unaltered. Enquiries should be addressed to crown.copyright@qld.gov.au

The information contained herein is subject to change without notice. The copyright owner shall not be liable for technical or other errors or omissions contained herein. The reader/user accepts all risks and responsibility for losses, damages, costs and other consequences resulting directly or indirectly from using this information.

For further information, please contact the Office of Liquor and Gaming Regulation on 13 QGOV (13 74 68) or visit www.business.qld.gov.au/industry/liquor-gaming

1 Introduction

- 1.1 The objective of these guidelines is to ensure that consoles supplied to Queensland Clubs and Hotels are safe, secure, reliable and acceptable for gaming.
- 1.2 The specifications contained in this document are guidelines only.

2 Console Guidelines

- 2.1 The minimum width and depth of a console must be at least that of the gaming machine fitted to the console, keeping in mind the additional width provisions to allow unobstructed door opening of gaming machines.
- 2.2 When designing carousels, benches, etc., the dimensions specified in section 2.1 may be allocated for each machine.
- 2.3 Individual consoles should have 2 side walls, a rear wall, a front wall and a top and floor. **The rear and side walls should all be load bearing.** There may be special circumstances where console tops and front walls can be shared. See Section 5 – Console Configurations.
- 2.4 The top of the consoles must be cut in accordance with the gaming machine manufacturer's instructions.
- 2.5 The cut outs in the console top may be covered in order to prevent access to the inside of the console prior to installation. *Ideally, the cut-outs should be made before lamination takes place.*
- 2.6 Consoles should be constructed to enable secure fastening to adjacent consoles. In addition, holes for the passage of fibre optic cables to adjacent consoles should be provided and in accordance with Figure 1 in section 7.
- 2.7 Note that the centre of gravity of an EGM is usually towards the front. As a safety consideration, ensure that any overhang at the front of a console is not excessive.
- 2.8 Consoles should have a door at the front to allow access to a cash box securely located inside.
- 2.9 The console door should be at least 250mm in height.
- 2.10 A horizontally hinged console door should be the full width of the console, with the hinge located at the bottom of the door.
- 2.11 The console door should be at least 0.13 m² in area.
- 2.12 The entire internal area of the console should be easily accessible via the console door opening for the purpose of installation and maintenance of cabling and mains power.
- 2.13 Consoles that are vertically hinged should have an 80mm x 50mm area (minimum), located on the opposite side of the hinge, to provide for the mounting of door sensors from any manufacturer on the role of recognised manufacturers. Such door sensors should be mounted within the console on the opposite side to the hinge so that the cash box will be unobstructed.

- 2.14 Horizontally hinged console doors should have provision for a door sensor on the opposite side wall furthest away from the cashbox area.
- 2.15 Horizontally hinged consoles should have a false floor, slightly higher than the position of the hinge, such that the cash box does not catch on the hinge as it is being withdrawn from the console.
- 2.16 Consoles should be sturdy and able to support at a minimum, the weight of an Electronic Gaming Machine (EGM) for an indefinite period. This includes any additional weight that may be applied – for example, patrons leaning on the machine at the same time (in addition, it would not be unlikely for a technician to put his/her full weight on a console in addition to an EGM). As an indication, some heavier EGMs weigh more than 130kg with a full hopper. Particular attention should be given to ensure that the door does not catch on the roof of the console, and that the console roof will not bow excessively with time. A centre support may be necessary to meet this objective.
- 2.17 The minimum allowable material thickness should be 16mm if the construction material is wood or similar strength material.
- 2.18 Any adhesives utilised should be water resistant and have a high bond strength.
- 2.19 A single heavy duty hinge, of 1.2mm thickness or greater, should be used for the console door. If the hinge is to be horizontally mounted, it should be the same length as the door. If the hinge is to be vertically mounted, it should be the same height as the door.
- 2.20 The hinge should be secured inside the console and not externally.
- 2.21 It should not be possible to disassemble or remove any section of the console without first accessing the interior of the console. This is to ensure for security reasons that the interior of a closed and locked console, cannot be accessed except via the console door.
- 2.22 Measures should be taken to ensure the hinge pin cannot be removed e.g. by using a hammer and nail.
- 2.23 Hinges should be securely affixed to the console and console door using appropriately gauged screws or bolts.
- 2.24 Secure door stops should be provided to ensure that the door cannot be forced inward (e.g. kicked in). All sides of the door should be supported except for the hinge side.
- 2.25 Consoles should be suitably finished and have no exposed access to the interior.
- 2.26 Console doors should be fully recessed to prevent entry of wires or other such objects that may be used to illegally obtain coins or to gain forced entry to the console.
- 2.27 Consoles should be constructed so as to prevent twisting and/or bending to gain access. The door should not catch if the console (with machine) is placed on a slightly uneven surface.
- 2.28 A hole of 50mm diameter should be provided in the back wall of the console to enable passage of the gaming machine's power cable. This should be located such that the cash box will not damage the cable when it is in place. The hole should be centred vertically on the left hand side.

- 2.29 The console should have an internal space of at least 330 (w) x 330 (d) x 200 (h) mm, on the left hand side, which is readily accessible through the console door. (This space is in addition to the space taken up by the cashbox.) A box of the above dimensions should be able to be inserted or removed from the console via the door.
- 2.30 The cash box should be positioned centrally under the cash box hole (the hole through which coins flow to the cash box). Otherwise, a funnel or chute should be used to direct coins to the centre of the cash box, the method employed should ensure that all coins are adequately directed to the cash box.
- 2.31 Consoles should have provisions to assist the correct positioning of a cash box within the console to ensure there is no chance of coin spillage. The cash box should only have one possible location within the console.
- 2.32 Consoles should have a barrier at the rear of the console to prevent the cash box from hitting the rear wall and damaging the fibre-optic / power cables.
- 2.33 Consideration should be given to the ease of removal of a full cash box. Refer to the Workplace Health and Safety Act, 1990 and the Code of Practice for Manual Handling.
- 2.34 Consoles should be installed flush with walls. Skirting boards should be taken into account.
- 2.35 Consoles should have a recess at the rear of the console, as per Figure 1 in section 7.0. ***This recess is to provide a pathway for the 240v power cables to the machines.***
- 2.36 The instructions to electricians in Appendix A should be included with each console supplied, and should remain in the console until the installation is complete.
- 2.37 While in the open position, horizontally hinged console doors should not allow any person to be able to lean or kneel on the door.
- 2.38 While in the open position, console doors should not obstruct the area in front of the console.
- 2.39 Full length, vertically hinged (side opening) console doors should not be used.
- 2.40 The hinge of a vertically hinged console door should be able to cope with the weight of the console door for an indefinite time period.
- 2.41 The hinge of a vertically hinged console door should be of the wrap-around type.
- 2.42 Footrests for patrons may be incorporated in the design of the console so long as they do not reduce the safety or security of the console.

3 Cashbox Specifications

- 3.1 Cash boxes should be equipped with a carry handle/s.
- 3.2 Cash boxes should be of a robust nature.
- 3.3 Cash boxes should be of an appropriate height to ensure that there is no chance of coin spillage.
- 3.4 Removal of the cashbox should not interfere with the door sensor.
- 3.5 A cashbox should be supplied with each console.
- 3.6 Cash boxes should be able to be directly withdrawn from the front of the console, without the need for manoeuvring around supports, walls or other obstacles.

4 Keys and Locks

- 4.1 Consoles should not be supplied with locks fitted.
- 4.2 A hole in the console door should be provided and be of such dimensions to permit the installation of a lock approved by the Office. The dimensions of the lock are indicated in Figure 3 in section 7. A list of approved locks can be found on the OLGR web pages.
- 4.3 With the console door closed and locked with an approved lock installed, there should be no movement in the door and the door should be held closed firmly by the locking mechanism.
- 4.4 Vertically hinged console doors should have the hole of section 4.2 located centrally on the side of the console door opposite to the hinge.
- 4.5 Horizontally hinged console doors should have the hole of section 4.2 located centrally on the top of the console door.
- 4.6 A keyed metal plate of appropriate thickness, with the dimensions of Figure 2 in section 7 should be secured to the inside of the console door, around the hole of section 4.2.
- 4.7 This metal plate should be fixed in a minimum of two points.
- 4.8 If the hole to accommodate the lock is recessed in any manner, then a metal ring (lock surround) should be provided with the console.
- 4.9 The dimensions of the lock and lock-cam that should be placed in the console are illustrated in Figure 3 in section 7.
- 4.10 A metal striker plate of a suitable gauge (minimum 70mm) should be used as a means of securing the lock cam, and thereby securing the door. The plate should also be centrally located with respect to the hole specified in section 4.4.

- 4.11 The metal striker plate of section 4.10 should be positioned so that there will be no play in the console door when the door is closed and locked.
- 4.12 The hole of section 4.2, and the metal striker plate of section 4.10, should be used in conjunction to provide a means of securely locking the console door.
- 4.13 For information only, a list of locks that meet the Office's guidelines is available for download from the OLGR web pages.

5 Console Configurations

- 5.1 Only consoles that conform to the guidelines in this document should be used in carousel configurations or any other configurations. In such configurations, shared console tops and/or shared console front panels are preferred.
- 5.2 No configuration should have a void *of any kind*.
- 5.3 Gaps in between consoles should be securely filled in all configurations. Any voids that expose gaming machine related cabling should also be filled.
- 5.4 Sharing of console walls should not occur in any console configuration. This is to ensure that the load-bearing walls and support structures of each console are present for each gaming machine.
- 5.5 If shared console tops or front panels are used, each console unit should be at least as strong as if the console were a stand-alone unit.

6 Automated Door Systems

- 6.1 An Automated Door System should be at least as secure as the same console using a manual door system.
- 6.2 In addition to an Automated Door System, there should also be a secure method to manually open and close the console door.

7 Diagrams

The plans detailed herein provide external dimensions only. Consoles supplied should be structurally sound. Dimensions shown in the diagrams throughout this section are in millimetres. **Diagrams are not to scale.**

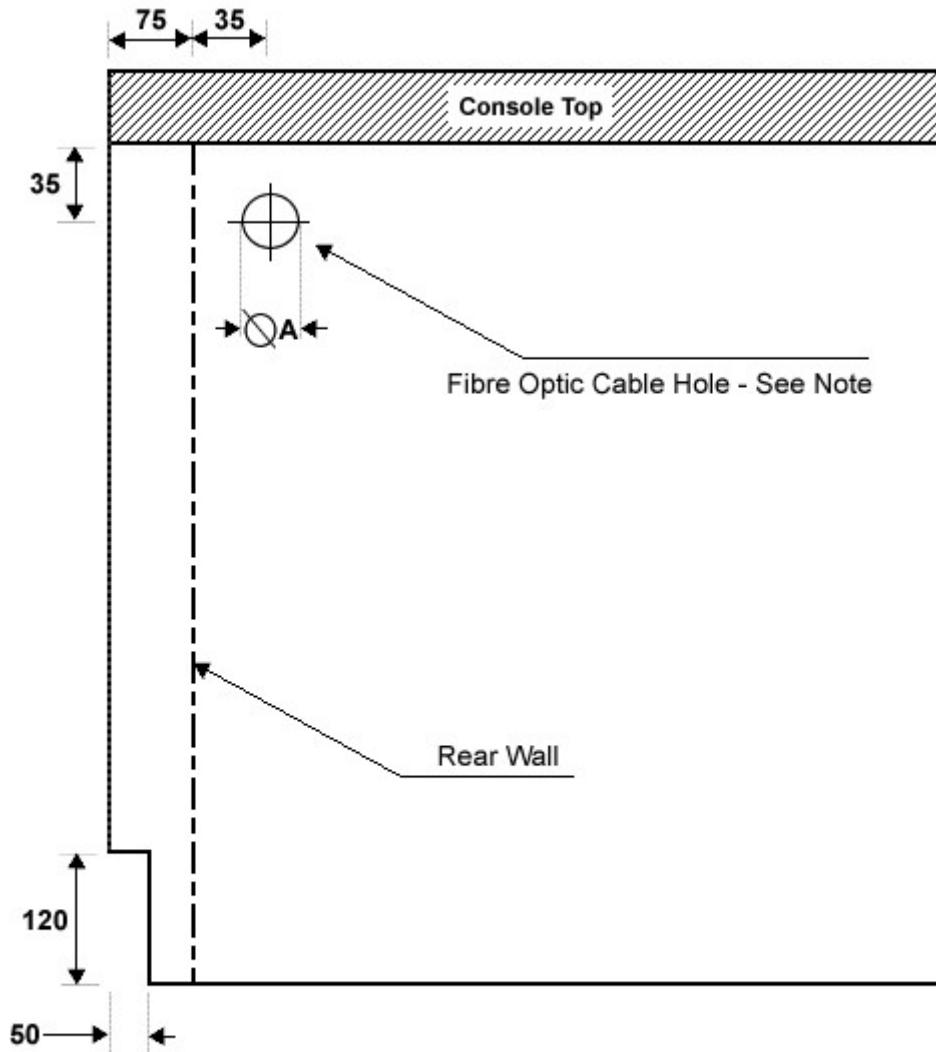

Note:
If a console is between 2 other consoles, the diameter of $\varnothing A$ must be between 40 - 50mm. Consoles that are not in between 2 other consoles (eg. at the end of banks), must not have these holes present in the publicly exposed wall.

Rear gable recess should be 250mm high - many require cutting out on site to accommodate larger than standard skirting boards - 50mm deep works fine

SIDE ELEVATION

Figure 1

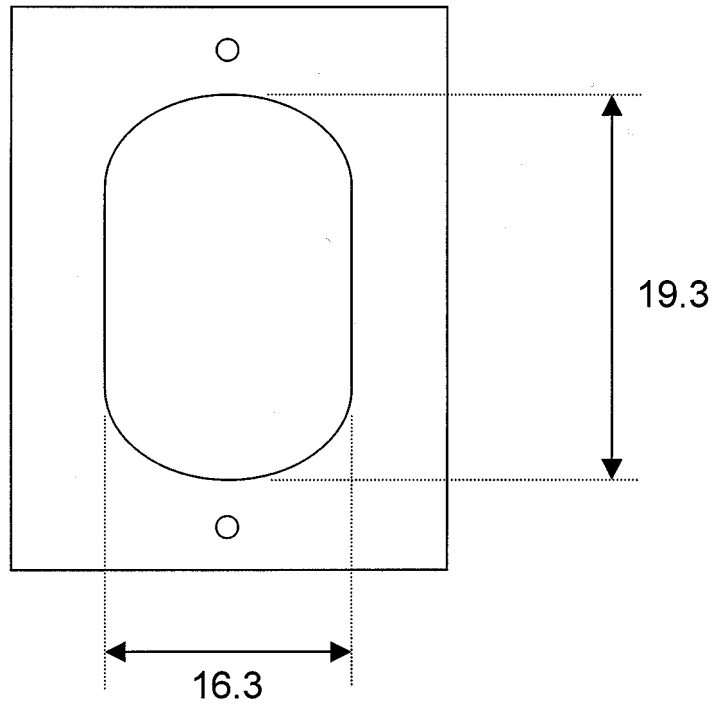

KEYED METAL PLATE

Figure 2

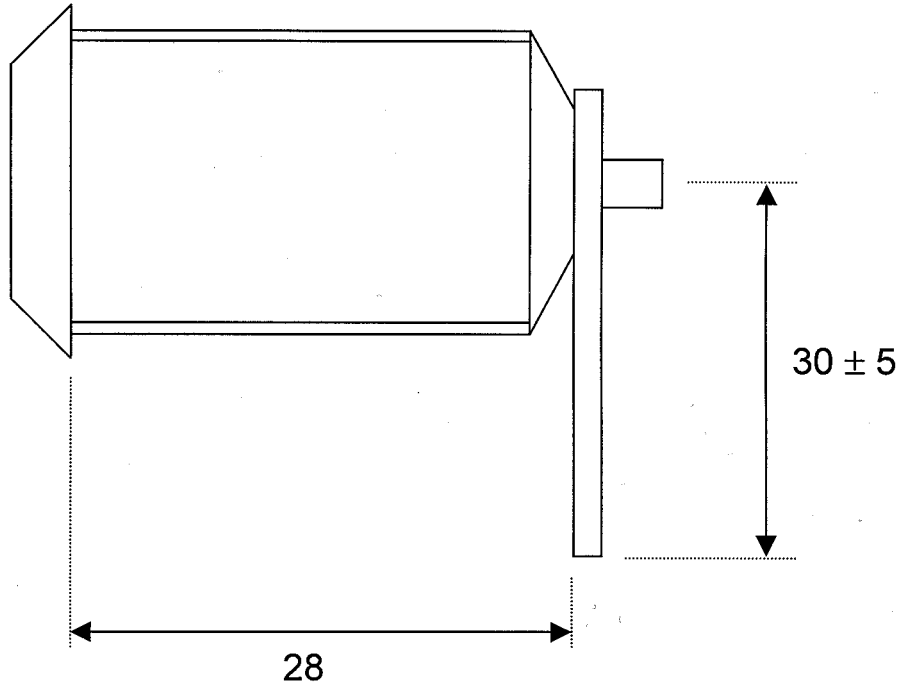

SIDE ELEVATION

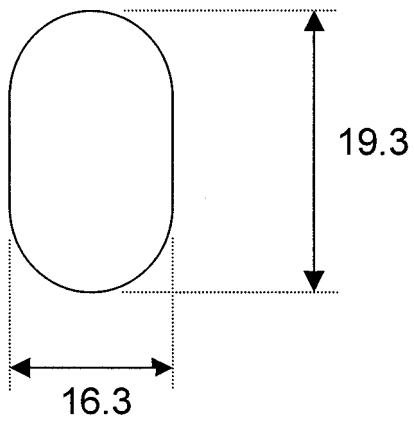

Cross Section of Lock Barrel

Figure 3

8 Glossary

| Term | Meaning |
|----------------------------------|--|
| Automated Door System | An Automated Door System incorporates mechanical and/or electrical devices that are used for the following purposes: (a) Remotely lock/unlock console doors (b) Remotely open/close console doors, or Any combination of (a) or (b) |
| Console | A console is a secure and robust cabinet on which a gaming machine is fastened, and through which fibre optic communication cables and power cables run. Consoles have doors to enable access to a cash collection device (commonly referred to as a cash box). The console doors are monitored by the gaming machine. |
| Certificate of Conformity | A document certifying that goods or products conform to the relevant rules and specifications. |
| Door Sensors | Sensors which alert the gaming machine when the console door is opened. These sensors are continuously monitored by gaming machines. |
| Role of Recognised Manufacturers | A role of gaming machine manufacturers that are currently approved to sell product to the Queensland market. |
| Gaming Machine | A gaming machine is also known as a "Poker Machine", "EGM" (electronic gaming machine). |
| Cash Box | A device used for the collection of coins that is located within the locked area of the console. |
| Carousel Configuration | A carousel is a configuration of consoles that may form any sort of loop. |
| SSO | Switched Socket Outlet, formerly referred to as the GPO. |
| Central Void | The central void of a carousel configuration is that area enclosed by the loop of consoles. Central voids are not preferred in Queensland. |

Appendix A

Instructions to Electricians

Refer to section 2.36

**DO NOT INSTALL SSOs
BEHIND THE CASH BOX AS
POWER CORDS MAY BE
DAMAGED WHEN THE CASH
BOX IS INSERTED.
ENSURE SSOs ARE ALWAYS
ACCESSIBLE**

The Switched Socket Outlet (S.S.O.) should be placed on the inside of the console on the back wall preferably directly over the 50mm hole which is located on the left side.

This 50mm hole on the back wall may be used to route the power cable from the outside to the interior. The cable may not be routed through the side wall from another console.

Take care when positioning the S.S.O. that it will not interfere with the cashbox, any gaming machine bolts, or any other equipment that may be placed inside the machine.

Revision History

| Version | When | Who | Description |
|---------|------------|-------|--|
| Initial | 01/04/2000 | | Initial Release. |
| 1.0 | 10/07/2000 | | Added Revision History, and updated approved lock list to include the Abloy Exec. |
| 1.1 | 09/05/2003 | RLL | Removed universal template. Removed approved locks. Both the above are now separate docs. General Changes. Fixed formatting. Merged checklist into document. |
| 1.2 | 18/07/2003 | RLL | Made changes as requested by John Woodall including a general review. |
| 1.3 | 15/09/2004 | MB | General update. |
| 1.4 | 02/06/2009 | JM | Following representation from industry, new draft to cater for new developments |
| 1.5 | 29/07/2010 | RLL | Updated to new DEEDI document template |
| 1.6 | 07/12/2011 | MM/LC | Changed from Requirements to Guidelines Corrected numbering issues from 1.5 update |
| 1.6.1 | 12/4/16 | JG | Updated to new JAG report template |
| 1.7 | 13/1/2023 | BR | Remove reference to universal console template (refer to section 2.4). Updated front and cover page. |